

February 2025

A Monthly Publication of the Carrollwood Civic Association



the

Carroler



Grab your best Hawaiian shirt and join us at White Sands Beach!

March 8

6 p.m. to 9 p.m.

(Adult Only Event)



Notice of Board Meetings

Monday, February 10, 2025

CRD Meeting: 6:30 p.m.

CCA Meeting: 7 p.m.

Carrollwood Rec Center • 3515 McFarland Road

Residents welcome to attend.

Carrollwood Civic Association
Carrollwood Recreation District
3515 McFarland Road
Tampa, Florida 33618
www.originalcarrollwood.com
www.originalcarrollwoodCRD.com

Scan here.



Read online!

the
Carroler

CCA News



John Schinka



Josh Shaffer



Corey McKeown



Jerrod Mills



Eric Pellenbarg



Matt Enering



Kristin Nail



Bryan Huls



Jared Jones



Luke Haydel



Neill Boyd



Adrianne Enering



Ethan Pliskow

By John Schinka, CCA President

Your CCA Board kicked off the year with a productive January meeting. The Board confirmed its officer positions for this year and we were pleased to have residents with us during the meeting. We discussed our long-term planning which includes continued efforts to replenish the canopy of trees in our neighborhood through a county grant, as well as efforts to lobby the County for much needed road improvements. We also discussed a goal to increase neighbor involvement in *The Caroler* articles

– so if you have fun items to share, please contact us. As always, we look forward to an active spring social calendar.

If you're looking for more information, be sure to check out our website at www.originalcarrollwood.com and send us an email to get added to our mailing list at cca@originalcarrollwood.com. We also encourage you to sign up for our text messages to get neighborhood updates in real time! 

CALLING ALL NEIGHBORS!

We are looking to add some new and exciting content to *The Caroler* in the upcoming months. We have a few ideas for articles.

We would love your help to contribute to some of these!



2. REMARKABLE RENOVATIONS —

Many homes in our neighborhood have gone through amazing transformations and facelifts. If you would like to share the work you've done on your home (exterior curb appeal or backyard renovations), send before/after photos and a small blurb about the work you've done to improve the appearance of your home.

Please e-mail all submissions to Kristin Nail kristinnail@originalcarrollwood.com

1. YOUNG NEIGHBOR AWARDS AND ACHIEVEMENTS —

We would love to highlight some kids in the neighborhood who have earned awards or proud of something they have achieved. For example: winning a soccer tournament, making a travel baseball team, district speech competition winner, learning how to ride a bike for the first time, etc. No achievement is too small! Send in a photo and blurb about your child and we will put it in a future issue.

3. NEWCOMER SPOTLIGHT —

If you have recently moved in the neighborhood (within the last year or so), we would love to get to know you! Email Kristin Nail at kristinnail@originalcarrollwood.com and she will send you some short/easy interview questions for a spotlight article.

Thank you! Look forward to seeing more of you in *The Caroler*.

Stay up-to-date with the Crime Watch/Events

crimewatch@originalcarrollwood.com |  Original Carrollwood Civic Association
www.facebook.com/groups/CarrollwoodCivic | Text UPDATES to (813) 640-4655 to receive text alerts



Mark Snellgrove



Dan Seeley



Mark Georgiades



Kristy Taylor



Jared Brown



Matt Lavisky



Dr. Anna Brown



Jack Griffie



Kevin Shidler



By Jared Brown

Exciting Improvements Coming to White Sands Beach in 2025

Big changes are coming to White Sands Beach in 2025! The CRD Board is excited to announce the installation of brand-new custom entry and exit gates enhancing both the security and aesthetic appeal of our beloved beach area. These state-of-the-art gates will feature an electronic access system designed to make entry and exit more convenient and secure for residents.

The new system will operate via a modern key fob system, ensuring seamless access for residents. In addition to the main gates, a pedestrian gate will also be installed offering easy access for those

traveling on foot. Whether you're heading out for an early morning walk or enjoying a sunset with your family, the upgraded gates will provide reliable and efficient access.

Construction is set to begin in February with a targeted completion date prior to spring break. The timing has been carefully planned to minimize disruption while ensuring the gates are ready in time for one of the busiest and most enjoyable times of the year.

We look forward to these improvements and believe they will add value, convenience, and a sense of pride for all who visit White Sands Beach. More information regarding the key fob distribution process will be shared with the Community as we move closer to completion.

Thank you for your continued support as we work together to enhance our beautiful Community! 

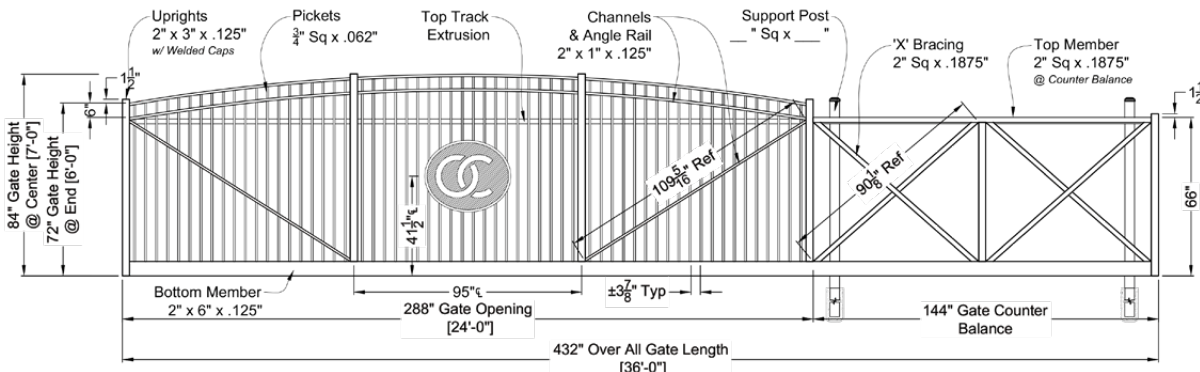
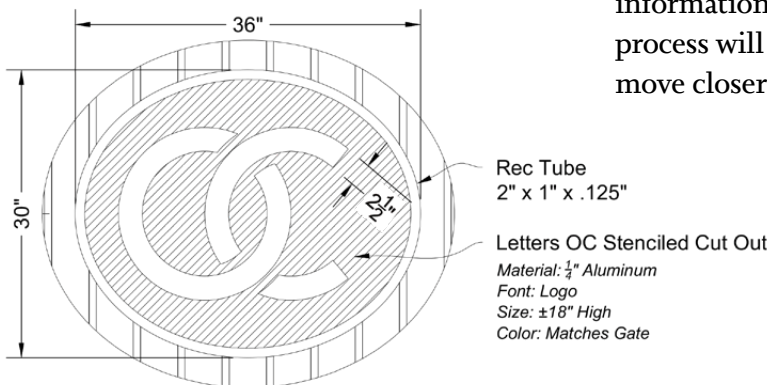

COMMUNITY CONTACT INFORMATION

Carrollwood Civic Association
www.originalcarrollwood.com

BOARD OF DIRECTORS

President John Schinka 813.503.1258
 JohnSchinka@originalcarrollwood.com
 Vice President Josh Shaffer 813.493.1244
 & Long-Range Planning JoshShaffer@originalcarrollwood.com
 Secretary Corey McKeown 813.951.4910
 corey@originalcarrollwood.com
 Treasurer Jared Jones 727.247.8737
 JaredJones@originalcarrollwood.com
 Legal Eric Pellenbarg 703.448.4121
 EricPellenbarg@originalcarrollwood.com

COMMITTEES

Crime Watch Neill Boyd 813.767.2694
 Crimewatch@originalcarrollwood.com
 Newcomers Kristin Nail 813.205.0541
 KristinNail@originalcarrollwood.com
 Lake Carroll Bryan Huls 813.930.0044
 BryanHuls@originalcarrollwood.com
 Construction & Dock Permitting Matthew Enering. 415.505.8570
 MatthewEnering@originalcarrollwood.com
 Social & Events Jerrod Mills 727.243.0188
 jerrod mills@originalcarrollwood.com
 Standards Enforcement Ethan Pliskow 813.205.2410
 ethanpliskow@originalcarrollwood.com
 Yard-of-the-Manth Adrienne Enering. 813.981.1126
 adrienne@originalcarrollwood.com
 Members-at-Large Luke Haydel 813.482.8111
 lukehaydel@originalcarrollwood.com

Carrollwood Recreation District
www.originalcarrollwoodCRD.com

BOARD OF TRUSTEES

President Mark Snellgrove 813.846.0424
 MarkSnellgrove@originalcarrollwoodCRD.com
 Vice President Dr. Anna Brown 813.931.9651
 AnnaBrown@originalcarrollwoodCRD.com
 Treasurer Mark Georgiades 813.240.5554
 georgiades@originalcarrollwoodCRD.com
 Secretary Kristy Taylor 813.503.8165
 KristyTaylor@originalcarrollwoodCRD.com

COMMITTEES

Community Development Jared Brown. 570.590.6119
 JaredBrown@originalcarrollwoodcrd.com
 OC Park Matt Lavisky 813.675.5292
 MattLavisky@originalcarrollwoodcrd.com
 Grounds Dan Seeley 813.293.3558
 DanSeeley@originalcarrollwoodCRD.com
 Rec Center/Tennis Courts Dr. Anna Brown 813.504.3713
 AnnaBrown@originalcarrollwoodCRD.com
 Scotty Cooper Park Jack Griffie 813.503.4552
 JGriffie@originalcarrollwoodCRD.com
 White Sands Beach Kevin Shidler 813.931.1662
 KevinShidler@originalcarrollwoodCRD.com

Carrollwood Recreation Center

3515 McFarland Road; Tampa, FL 33618 • 813.932.1257 • Fax: 813.935.9057
 office@originalcarrollwoodCRD.com • Office Hours: Monday through Friday, 9 a.m. to 1 p.m.

Hillsborough County Sheriff's Office
Non-Emergency • 813-247-8200



Original Carrollwood
 Civic Association

www.facebook.com/groups/CarrollwoodCivic



CAROLER AD SIZE & RATES

SIZE	SPECS	RATE PER ISSUE	
		REGULAR*	PRINT
Full page	7.5" w x 10" h	\$225	\$425
1/2 page	7.5" w x 4.875" h	\$140	\$235
1/4 page	3.625" w x 4.875" h	\$75	\$145
1/8 page	3.625" w x 2.375" h	\$45	\$80

PREMIUM PLACEMENT:

Inside Front or Back Cover, Page 3	\$275	\$475
Back Cover	\$275	\$550

Classifieds: \$20/month for 25 words

Annual Print Subscriptions to The Caroler

To receive a printed copy of *The Caroler* mailed directly to your mailbox every month, click or scan below to pay online, or mail your \$96 check made payable to RoxC LLC with information below, to: Roxanne Clapp, Caroler Editor, 2816 Overlook View Rd, Walland, TN 37886

CAROLER SUBSCRIBER INFORMATION:

Last name: _____
 First name(s): _____
 Address: _____
 Email: _____

SUBSCRIBE NOW!



CLICK OR SCAN TO
 SUBSCRIBE

Receipt of subscription payment prior to the 15th of the month will ensure following month's delivery.

Electronic delivery of *The Caroler* is provided at no cost to residents via OC website, with notification via community e-mail and OC Facebook page.

EMERGENCY SERVICE 24/7

We install outdoor showers and outdoor sinks!



844-TO-FLUSH
ChannelsidePlumbing.com

- Cast Iron Sewer Rejuvenation Specialist
- Drain Stoppages
- Water Heaters
- Pipe Repair & Replacement
- Fixture Replacement
- Bathroom & Kitchen Remodeling
- Pipe Leak Detection and Repair



Dedicated to Providing Affordable, Quality
and On-Time Service to Our Customers

Call Us Toll FREE Today!

1-844-863-5874

se habla
Español



Owner operator lives in Carrollwood.
State master license numbers CFC1429399 | CAC1821976



PAUL & MELISSA RUSSO
11505 Lake Ridge Road

Q | When did you move to Original Carrollwood and what have you enjoyed most about living here?

A | "We moved to Original Carrollwood in 2003. We love all of the year round family events. It is the best neighborhood to raise your family."

Q | What do you love most about your home and yard? Why?

A | "I love that this is the home that we raised our three children in. The home itself is a Cape Cod style which is considered an American Classic beach house. The trees and plants coordinate with the style of the home."

Q | When thinking of all the time you have spent in your yard, do you have a favorite memory?

A | "Our favorite memory is sitting in our front yard watching many parades."

Q | Any fun facts, hobbies or words of wisdom you would like to share with your neighbors?

A | "Cherish every moment living in the most beautiful neighborhood to raise your family."

Email your nomination to: YardoftheMonth@OriginalCarrollwood.com

Include: Address of nominated yard • Reason for nomination • Your name, phone number, & email address • If possible, please include a photo of the yard with your nomination. Thank you! Nominations can also be made at the Community Center, at Board Meetings or by visiting our Community website: www.OriginalCarrollwood.com

CAMP IDS

AT CORBETT PREP

STUDENTS ENTERING PREK3 THROUGH 8TH GRADE

SUMMER 2025

6 WEEKS OF OPTIONS
JUNE 10 - JULY 19

100+ FULL- AND HALF-DAY CAMPS
BEFORE- AND AFTER-CARE

813.961.3087 www.corbettprep.com campids@corbettprep.com

Corbett Preparatory School of IDS • 12015 Orange Grove Dr. Tampa, FL 33618

this & that



OC REAL ESTATE

By Clay Brown
 Managing Broker/Market President
 Berkshire Hathaway HomeServices
 Florida Properties Group



OC Listings as of *The Caroler* deadline

Compliments of Clay Brown, Realtor®

A=Active; P=Pending; S=Sold in the last 30 days

Status	Address	Htd Sq Ft	Price
P	10315 Lake Carroll Way	4217	\$975,000
P	3014 Samara Drive	2,328	\$837,500
S	3418 Picwood Rd	1692	\$525,000
S	10325 Reclinata Lane	2548	\$640,000

Greetings Carrollwoodians!

While February still may be considered winter, in real estate, the market is already starting to heat up! Whether you're planning to buy, sell, or just keeping an eye on trends, this time of year is all about preparation. With spring just around the corner—traditionally the busiest season for real estate—February is the perfect time to assess your goals and get ahead of the competition.

Last month, we talked about the power of starting small and setting realistic goals. Tackling manageable steps is a great way to build momentum and set yourself up for success, and the same approach applies to navigating the real estate market. Now that February is here, it's time to take those small steps and turn them into forward motion as we head toward the peak season. The chart below shows the ebb and flow of Pending Sales over the last few years, offering valuable insights into seasonal trends...

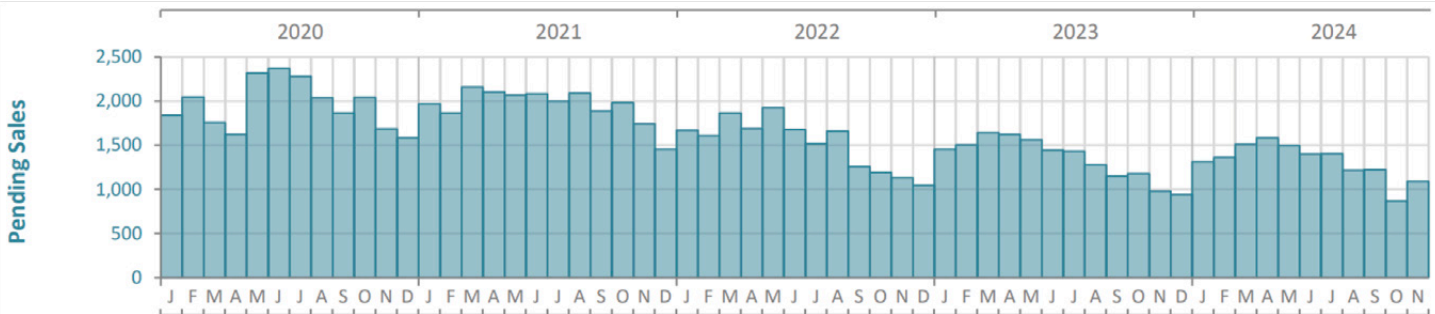

As you can see, February and March historically mark the beginning of an upswing in pending sales. This pattern reflects increased activity as buyers and sellers prepare for the spring market. If you're thinking about selling your home, now is the time to start preparing. With more buyers entering the market over the coming weeks, ensuring your home is in top shape will help you stand out. Simple updates—like fresh paint or a deep cleaning—can make a big difference. Don't forget to consult with a real estate professional (hi there!) to strategize your pricing and marketing plan.

For buyers, this is your cue to get your ducks in a row. Meet with your lender to get pre-approved, narrow down your must-haves, and start keeping an eye on listings. With competition ramping up, being prepared can give you a serious edge when you find the right home.

The data shows us that while February is a time of preparation, March often brings a flurry of activity. Acting now, whether by listing your home or getting pre-qualified, puts you in a stronger position to navigate the market's inevitable pace. Real estate success often comes down to preparation and timing. Just like setting realistic resolutions, taking manageable steps now can help you achieve your goals without feeling overwhelmed. And if you're ready to dive into this year's market but aren't sure where to start, I'm here to help. Give me a call—I'd love to be part of your journey.

Sugar Wing

WING IT, STRIP IT, DIP IT.

In the Publix plaza on Gunn Hwy & Anderson Rd

Sugar Bird Sandwich

Wah-Sabi Sandwich



Honey Buffalo Wings



Wouldn't you
Love some
chicken
right
now?

Atomic Sandwich

Naked Bird
Sandwich
Chipotle BBQ
Wings

Carolina Mustard
Wings



www.mysugarwing.com
813-726-4010

Experience the Innovation of Chamberlain High's 3DE Curriculum at Market Day

by Nancy Leach

Chamberlain High School's groundbreaking 3DE (Three Dimensional Education) program is transforming high school education. Recognized as one of the top programs in the country, it's a model being studied by school districts nationwide to prepare students for the demands of the new economy.

Currently, nearly half of Chamberlain's student population participates in this innovative curriculum. A highlight of the program is its focus on entrepreneurship, requiring every 11th grader to start and manage a business alongside up to five classmates. With real-world mentorship from industry leaders—including the CEO of Raymond James Bank and Wall Street executives—students gain invaluable insights and skills.

Chamberlain is the only school in the country to integrate real money into its 3DE program, making the risks and rewards truly authentic. Each team pitches their ideas to "sharks," who provide funding and guidance. Students repay their sharks before keeping any profits, with top-earning teams earning cash bonuses of up to \$100 per participant.

You're invited to experience the excitement firsthand at Chamberlain's 3DE Market Day on February 27 from 9–11 a.m. in the school gym. Students will sell their products, showcasing the entrepreneurial spirit that defines this program.

In addition, the Chamberlain High School Legacy Alliance is proudly sponsoring four scholarships for top 11th-grade students to attend the University of South Florida's Business Entrepreneurship Camp this summer.



Join us and witness the future of education in action! Don't miss this incredible event.

Learn more at www.hillsboroughschools.org/domain/2739



3DE Market Expo
Feb 27 9am-11 am
Location: Chamberlain's Gym
Celebrating our 11th Grade 3DE students as they showcase their companies!
Merchandise available for purchase.



YOGA STUDIO
MOON DROP

JOIN OUR KIDS CLASSES

\$199 - 9 week session plus 2 Kids Nights!

Wednesdays - 5:45-6:45p - Ms. Beth

Saturdays - 10:30-11:30a - Ms. Stephanie

-- adult classes at the same time!

PLUS MORE FOR FAMILIES!

Mini & Me - Yoga with your little one

Mindful Mamas - Yoga, Breathwork, & Support for Pre/Post Natal Mamas

Kids Night Out - Fun for them, a night out (or in) for you

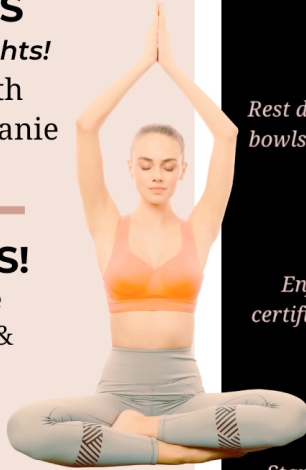

10512 n dale mabry hwy (behind einstein bagels)
 moondropyoga.com ~ 813-269-9642

YOGA TEACHER TRAINING
 INFO SESSIONS

COMING IN 2025

EVENTS



Join our story club & crochet circle!

Sound Bath

Rest deeply as a sound therapy practitioner uses singing bowls and other instruments to help restore your peace.

Reiki & Restore

Enjoy the deep, restorative yoga stretches while a certified Reiki practitioner heals & realigns your energy to emerge enlivened.

Yoga Beats

Start your weekend with a new Yoga Experience - an invigorating vinyasa practice set to a vibe-y playlist. All levels welcome!



GOLD
 INVISALIGN
PROVIDER
2024

Call to schedule your appointment today!
813.265.2273

Delivering the highest quality care for the entire family, in a calm, comfortable environment.



Dr. Alisha Anand



Dr. Amy Creech-Gionis

- Implants placed and restored
- Invisalign Top 1% Provider
- Sedation options for anxious patients
- Smile makeovers with beautiful porcelain veneers
- Loose dentures anchored with implants
- Preventive and gum disease treatment

11123 N Dale Mabry Hwy.,
 Tampa, FL 33618

Also located in Westchase:
 11321 Countryway Blvd., Tampa, FL 33626



Scan me

Visit our website www.tampadentalwellness.net for more!



Stay Connected!

MAKE SURE YOU ARE RECEIVING ALL THE NEIGHBORHOOD NEWS

If you are a new resident or have not been receiving the Crime Watch/Events and Neighborhood emails, please contact: crimewatch@originalcarrollwood.com to get signed up. The emails contain Crime Watch notifications, The Caroler newsletter, social event information, and other neighborhood news.

Receive text message alerts about OC Events and OC Crime Watch Information: To subscribe, text UPDATES to (813) 640-4655 or visit oclinks.cc/texts or scan the QR Code >>>



You can also join our Facebook page for updates on neighborhood news and social events. This page is the same as the emails so you will not miss anything if you are not on Facebook.

You can search for Original Carrollwood Civic Association on Facebook or visit this link: <https://www.facebook.com/groups/CarrollwoodCivic>

New residents, please contact Kristin Nail: kristinnail@originalcarrollwood.com or cca@originalcarrollwood.com



Neighbor TO Neighbor

CLASSIFIED ADS

FULL ARRAY OF HANDYMAN SERVICES.

Storm cleanup. Hauling. Pressure washing, etc. Chuck Kim (OC homeowner). 813-352-1382.

ADD YOUR CLASSIFIED NEXT MONTH \$20 for 25 words. Deadline is the 10th of each month. Email: Caroler@roxc.graphics



Welcome Newcomer

Please contact **Kristin Nail, Newcomer Chairman** to receive a welcome packet.

kristinnail@originalcarrollwood.com
813.205.0541

HELP KEEP OUR RESIDENT DIRECTORY UP-TO-DATE

Here's the information we need:

Last name: _____

First name(s): _____

Phone number: _____

Address: _____

Email: _____

Email: _____

Names of children (optional): _____

Email your information to:

Directory@originalcarrollwood.com or drop it off at the Carrollwood Recreation Center 3515 McFarland Road

DIRECTORY UPDATES MADE QUARTERLY

Keep current for access to White Sands Beach. The guard service will be given a new directory quarterly and all passes issued by the business office will expire. The quarterly updates will not be mailed out, but only utilized between the Business Office and the guard service.

**Give Your Countertops,
Showers, & Floors
Some Love!**



ALL-OUT
REGROUT & STONE CARE



Call Today! **(813) 360-1192**
www.alloutregROUT.com

TURNING 65?

Questions about Medicare?

Turn to a neighbor you can trust



**OPEN ENROLLMENT
NOW**

We have over 50 Medicare Advantage and Medicare Supplement insurance carriers to provide the best plan for your individual needs.



Kevin Shidler

*Original Carrollwood homeowner for 34 years
and serving my community on the CRD Board
for 11 years.*

Kshidler@stream-insurance.com
813-624-8411 • Office 866-747-6691

stream-insurance.com

TAX PROBLEMS? TAX SOLUTIONS!

Call the
Tax Resolution Consultants

844-TAX-2828

813-203-9763

Pablo G. Martinez

Attorney & Counselor at Law
4145 W. Waters Ave. Tampa, FL 33614

WE ASSIST WITH:

- Offers in Compromise
- Innocent Spouse Relief
- Unfiled Income Tax Returns
- Installment Agreements
- Payroll Tax Problems
- Business Tax Problems
- Penalty Abatements
- Appeals
- Wage Garnishments
- Liens
- Property Seizures
- Levies

IRSDEBTFREE.COM
info@irsdebtfree.com

upcoming Social events



(to be updated with additional information/events)

2025

MARCH 8

Hawaiian Luau
(adult only party)
White Sands Beach

APRIL 5

Community Yard Sale

APRIL 19

Easter Egg Hunt
Original Carrollwood Park

Have questions or need information about any of the social events, email us at events@originalcarrollwood.com

We ask that you do not share our social events information publicly or post on other social media sites. We offer these events for our residents and close family/friends. Thank you.

~ CCA Social Committee



ANNUAL C EASTER EGG HUNT

April 19, 2025

Original Carrollwood Park!

Free specialty coffee drinks provided by Buddy Brew Coffee Truck!

This year's Easter Egg-citing Hunt will be held at Original Carrollwood Park on Saturday, April 19, starting at 10:00 a.m. In addition to donuts, coffee and water, we will have prizes for Best Bonnet, Handsome Hair & Festive Family. And a special prize for finding the Golden Eggs in each age group.

This unbeatable egg hunt will be broken up into three groups:

- 0-3 years old's (starting at 10 a.m.)
- 4-6 year old's (starting at 10:10 a.m.)
- 7 to 13 year old's (starting at 10:20 a.m.)

Bring your camera for pictures and enjoy a latte!

VOLUNTEERS NEEDED

We are in need of volunteers. All volunteers will collect service hours, and the bunny costume volunteer is paid \$30 plus service hours. All volunteers must be at the park by 8 a.m. on Saturday. Email events@originalcarrollwood.com to volunteer.

Adults & Volunteers – We will be setting up Friday late afternoon/evening. Email events@originalcarrollwood.com if you are interested in helping.

Thank you, CCA Social Committee

TEMPSTAR
Heating and Cooling Products

 **TRANE**
It's Hard To Stop A Trane.

Lloyd's Heating & Cooling, Inc.

Veteran owned

Serving the Tampa Bay area for over 25 years.

Lic.# CAC1816437

Stock | #126616841

813.631.1418 ♦ **Call4AC.com**
SERVICE ♦ **MAINTENANCE** ♦ **REPLACEMENT**

100% SATISFACTION GUARANTEED



CARROLLWOOD WINDOW & DOOR

Installing Trust One Window at a Time

- Replacements
- New Construction
- Energy Efficient Windows
- Hurricane Resistant Windows
- Entry Doors
- Patio Doors
- French Doors
- Sliding Doors



Call Today! 813-626-7676

6025 North US Hwy 301 - Tampa, FL 33610

www.carrollwoodwindow-door.com



HOLIDAY BOAT PARADE

Photos by Lawrence Davis



LUMINARIA on Peacock Lane

Photos by Mark Boghich



Help Maintain Lake Carroll Make a Donation

Residents! Help keep Lake Carroll clean and safe. Financial contributions are needed from everyone. Funds are used to offset expenses for vigorous water sampling and testing, and other lake maintenance and monitoring needs. Contributors are greatly appreciated and will be acknowledged in *The Caroler*.

LAKE FUND DONATION

Name: _____

Address: _____

Phone: _____

Amount: _____

Make funds payable to: Carrollwood Civic Association; 3515 McFarland Rd.; Tampa, FL 33618. Please include this form OR donate through PayPal on the OC website: www.originalcarrollwood.com

ACCIDENTS

Wrongful Death



CALL NOW!

Pablo Martinez
Attorney at Law P.A.

Hablo Español

813-231-0138



IT'S TIME WORKING OUT WORKED YOUR WAY. JOIN FOR \$1

 ANYTIMEFITNESSCARROLLWOOD
 AFCARROLLWOOD

813-264-1861
 11113 N DALE MABRY HWY
 (Next to IHOP)

GET STARTED TODAY
 Join us for a personalized plan and a coach who can help you along your journey. And a community who has your back.
ANYTIMEFITNESS.COM
1113 N DALE MABRY / TAMPA, FL / 813.264.1861

Membership purchase required. Terms, conditions & restrictions apply. See anytimefitness.com/offer for details. Offer ends 2/28/2025.



THE FLORIDA ORCHESTRA

Hough Family Foundation Masterworks

Tchaikovsky's PIANO CONCERTO NO. 1

Featuring Olga Kern
Feb 22 & 23



Florida Orchestra Benefit Concert

A GALA CONCERT WITH YO-YO MA



Feb 28
Ruth Eckerd Hall

Support your Florida Orchestra today
FloridaOrchestra.org/donate

FloridaOrchestra.org | 727.892.3337

THE Aesthetics Lounge and Spa

13801 N Dale Mabry Hwy, Tampa FL 33618
Located inside the Salon and Spa at Mystic Hair

Tox - Filler - Laser Hair REMOVAL -
IPL Facials - Microneedling - Skincare
- Weightloss Coaching - Chemical
Peels

NOT YOUR AVERAGE MEDICAL SPA. SUBTLE. NATURAL RESULTS.



 www.lookbeautifultampa.com
 [aestheticslounge_tampa](https://www.instagram.com/aestheticslounge_tampa)
 813-755-5772

Lipsey Road Block Party

Photos provided by Frank Deak

April 2014

Puzzles OF THE Month



There is a woman in a boat.
On a lake wearing a coat.
If you want to know her name,
it's on the riddle I wrote.
What is the woman's name.

Where did you see the hidden peacock in this issue?

Email your answers to
Caroler@roxc.graphics before February 10.
All who reply will have their name posted in
the next issue of *The Caroler*!

Congratulations to last month's players!

Terry Kor
Andrea and Jack Griffie
Barbara Kolar

Last Month's Answers: Location of the hidden peacock in the previous issue: Page 4

- ___ pudding is a traditional English Christmas dessert
- ___ can be made by boiling leftover bones
- Can come in loaves, buns, dinner rolls or sticks
- Hot apple ___ is a favorite holiday drink
- "Christmas is coming the ___ is getting fat"
- What you can make with the turkey drippings - watch out for lumps!
- ___ potato pie, sometimes with marshmallows
- Dinner can be served formally at a table or as a free-for-all ___
- Rich, creamy holiday drink
- This type of potato goes well with gravy
- Young children sometimes put ___ on their fingers and eat them
- Some Jewish people eat latkes or ___ pancakes during Hanukkah
- This holiday staple can make you sleepy after you eat it
- Sugar, chocolate, macaroon, shortbread
- Formed in a mold with fruit, or whipped with cream into a salad
- Buffet meal where everyone brings a dish or dessert
- Usually made into a pie, but the roasted seeds can be tasty too
- A rolled, delicious cake that started as a fireplace tradition
- Nothing is as good mom's ___
- Made with dried bread and spices
- In Germany, Christmas foods include spice cookies and ___
- Green bean ___ with french fried onions
- A traditional holiday food that some love and many joke about
- This holiday pie ingredient is mostly fruit and nuts, not beef
- Tropical fruit that can be found topping ham and pork
- Round, nut-covered dairy product to be attacked with crackers
- Eat as a sauce or jelly, or string the berries as to make a garland
- These types of houses are fun to make and decorate

PLUM
SOUP
BREAD
CIDER
GOOSE
GRAVY
SWEET
BUFFET
EGGNOG
MASHED
OLIVES
POTATO
TURKEY
COOKIES
GELATIN
POTLUCK
PUMPKIN
YULELOG
APPLEPIE
STUFFING
BRATWURST
CASSEROLE
FRUITCAKE
MINCEMEAT
PINEAPPLE
CHEESEBALL
CRANBERRIES
GINGERBREAD



Lipsey Block Party Organizers



Teri Arcuri and daughter; Dominic Wilson with daughter Louisa & Courtney Wilson, Krista Mills



Bobby & Kristy Taylor



Frank Arcuri, Frank Crum, and Frank Deak



Kristy Taylor, Lauren, Brian & Loretta Hughes



Katie, Elsie Rinehart

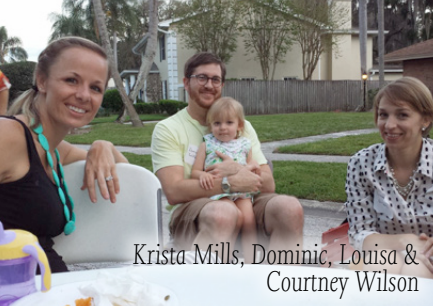

Krista Mills, Dominic, Louisa & Courtney Wilson



Janet Daggs, Cyndie Deak



Katie, Elsie & Scott Rinehart, Jerrod Mills, daughter Wilson, Al & Diane Ferris



Jason Freeman and Scott Rinehart

When is your block party?

10% OFF FOR OC RESIDENTS!

WINDOWS
SIDING
ROOFING
RESTORATIONS



CALL US TODAY!
813-492-6940
WWW.WEATHERSHIELDCS.COM
CGC1509568

FLORIDA POOL
HEROES

SAVING YOU FROM RETAIL PRICES



DON'T PAY RETAIL POOL STORE PRICES
SAVE ON POOL SUPPLIES DELIVERED FOR FREE*

✓ Set a delivery or install date that works on your schedule

✓ Flat Rate Installation starting at just \$19

✓ Subscribe and save on your regularly used chemicals

✓ Free delivery over \$75

CALL OR TEXT TODAY!
813-726-9464
www.yourpoolhero.com

SCAN FOR DISCOUNT



Wagging the Day Away

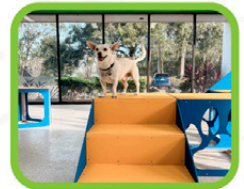
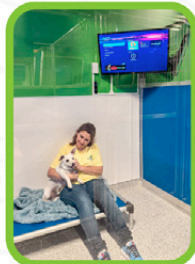

Boarding*

We prioritize the comfort and well-being of your pet. Our spacious, private kennels are equipped with cozy blankets and beds, ensuring a restful stay. For those looking for a more indulgent experience, our luxury suites offer exclusive amenities, including daily walks, cuddle time, bedtime treats, and even their own TV to enjoy!



Daycare*

Our Daycare program offers an exciting variety of activities, including a splash pad, an indoor pool, and spacious indoor play areas to keep your pet active and entertained. To ensure the best experience, we also offer additional enrichment add-ons tailored to your pet's needs. A temperament test is required prior to scheduling to ensure a perfect fit for your pet's personality and comfort.



Spa Services

We offer full-service bathing and pampering. Whether your pup needs a refreshing bath after a fun-filled stay or a special pampering session, our professionally trained staff is here to provide exceptional care. Call us for more information!

(813) 692 6655

thewaggingclub.com

13155 N Dale Mabry Hwy
Tampa FL 33618

frontdesk@waggingclub.com



*Private Daycare and Boarding available

White Sands Beach!

LUAAU PARTY



March 8
6 p.m. to 9 p.m.
(Adult Only Event)



**Food:
Pig Roast
& some sides**

Grab your best
Hawaiian shirt
and join us at
White Sands Beach
on March 8th
for our Hawaiian
Luau party!!

